

- (1) Liquid Crystal Display
- (2) ON/OFF push button
- (3) Push button
- (4) Push button
- (5) TEST Push button
- (6) Function selector switch
- (7) Terminal sockets
- (8) External Power supply jack (Optional)
- (9) Symbol for "CONTINUOUSLY ON"
- (10) Digital display with indication of decimal point and polarity
- (11) Symbols for displaying the selected functions
- (12) Display for selected function
- (13) Display for the unit of measured quantity
- (14) Over range Indication
- (15) Pointer for Analog indication
- (16) Scale for Analog Indication
- (17) Activated stop watch Indicator
- (18) Zero adjust indicator
- (19) Low battery indicator
- (20) Buzzer indication

8 (optional)

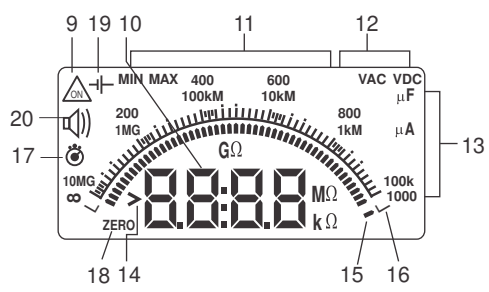

Contents	Page
1 Safety Features and Precautions	4
2 Initial Start-Up	5
3 Selecting Measuring Functions	6
4 Liquid Crystal Display	6
4.1 Digital Display	6
4.2 Analog Display	6
4.3 Backlit	6
5 Insulation Resistance Measurement (MΩ)	7
5.1 Preparation for measurement	7
5.2 Insulation resistance measurement	7
5.2.1 Manual Insulation resistance measurement	7
5.2.2 Continuous measurement for a pre-selectable time	8
5.3 Conclusion of measurement and discharging	8
6 Additional Features	8
6.1 Pre-selectable limit checks (Go / No-Go option)	9
6.2 Storing the measured resistance value	9
6.3 Minimum value and Maximum value "MIN/MAX" storage facility	9
7 Continuity Testing and Resistance Measurement	11
7.1 Continuity Testing	11
7.2 Low Ohm Measurement	11
7.3 Zero adjustment	11
8 Voltage Measurement (VAC/DC)	12
9 Default Live Circuit Warning	12
10 Stop Watch	13
11 Menu Structure	13
11.1 Description of Menu items	14
11.1.1 Setting the GoNoGo values	14
11.1.2 Setting the Timer values	14
11.1.3 To see the stored values	14
12 Specifications	15
13 Maintenance	18
13.1 Battery	18
13.2 Operation with mains Adapter (Optional)	18
13.3 Fuses	19
13.4 Housing	19

1) Safety Features and Precautions

You have selected an instrument which provides you with a high level of safety.

The *RISH* INSU 20 Analog-Digital Insulation Tester is manufactured in compliance with safety regulations IEC 61010-1/EN 61010-1/VDE 0413 part 1. When used for its intended purpose, safety of the operator, as well as that of the instrument, is assured. In case of incorrect use or careless handling, the safety of both user and instrument is not assured.

To maintain the safe and proper condition of the instrument and to ensure its safe operation, it is absolutely necessary to carefully and completely read these operating instructions before using the instrument. These instructions must be followed in all respects.

Observe the following safety precautions :

- * The instrument must be operated only by persons who understand the danger of shock hazards and know how to apply safety precautions. Shock hazards exist anywhere, where voltages of more than 30 V may occur.
- * Do not work alone in shock hazardous environment while carrying out measurement.
- * The maximum allowable voltage between any terminal sockets and earth is equal to 600 V for voltage and 1000V for Insulation resistance measurement.
- * Verify that the test leads are in good condition, e.g. no cracked insulation, no open circuits in the leads or connectors.
- * Measurements under moist ambient conditions are not permitted.
- * Do not exceed the permissible overload limits of the measuring ranges. Limit values can be found in the table in "12. Specification".



Safety Precautions for Insulation Resistance Measurement

- * The circuit under test **must** be switched off, de-energized, isolated **before** Insulation or Continuity tests are made.
- * The **TEST** button **must not** be pressed while connecting the test leads or while changing ranges.
- * The Voltage warning **does not function** while in STOP WATCH mode or in MENU structure.
- * During an Insulation test, connections **must not** be touched.
- * After insulation tests, capacitive circuits **must** be allowed to discharge **before** disconnecting test leads.
- * Test leads and crocodile clips **must be** in good condition, clean and with no broken or cracked insulation.



Meaning of symbols on the instrument

Warning concerning a point of danger
(Attention: observe documentation)



Earth



Continuous, doubled or reinforced insulation



EU Conformity Mark

Repair, Parts Replacement and Calibration

After opening the instrument, live parts may be exposed. Therefore, the instrument must be disconnected from the measuring circuit prior to opening its case for repair, replacement of parts or calibration. If repair or calibration cannot be avoided, unless the instrument is open and live, the work must be performed by a qualified person, who understands the danger involved.

Faults and Extraordinary Stress

When it is realized that the safe operation is no longer possible, take the instrument out of service and secure it against accidental use.

Safe operation is no longer possible -

- When the instrument shows obvious sign of damage,
- When the instrument no longer functions correctly,
- After a prolonged storage under adverse conditions,
- Due to severe stress due to transportation.

2 Initial Start-Up

Battery

Fit the instrument with the six 1.5V cells (IEC LR6 type) provided along with the instrument.

Before you use the instrument for the first time or after storage refer to section "3. Maintenance Battery"

Mains Adapter for external power supply (Optional)

Mains Adapter (Output : DC 9V, 500mA) can be connected for long term measurement (without usage of internal batteries).



**Isolated Adapter has to be used.
Do not use non-isolated Adapter.**

Connect the jack to the instrument and Adapter to the mains power supply.

Switching the Instrument ON

Instrument can be switched ON :

1. By pressing the ON/OFF button.
2. By changing the function selector switch from current position to desired function.

Switch-on is acknowledged by a sound signal. The instrument is now ready for operation.



Attention !

Before opening disconnect the instrument from the measuring circuit and ensure high voltage is not available on leads.

Automatic turn-off

Your instrument turn off automatically, if any of the keys or the function selector switch have not been activated for about 10 minutes in insulation resistance range and 5 minutes in other ranges.

How to prevent automatic TURN-OFF

In order to prevent automatic "TURN-OFF" select "CONTINUOUSLY ON" mode For this push TEST push button and the "ON-OFF" pushbutton together when switching ON the instrument.

The symbol  is displayed on the LCD to indicate this "CONTINUOUSLY ON" mode.

Switching the Instrument Off

Press "ON/OFF" pushbutton for a longer time.

3. Selecting Measuring Functions

The desired measuring function is selected with the Function selector switch.

4. Liquid Crystal Display

4.1 Digital Display

The digital display shows the measurement value and decimal point. The selected measuring unit and function are displayed.

4.2 Analog Display

The analog indication gives the dynamic performance of a moving coil mechanism. This is especially advantageous for the observation of measurement value fluctuations and for calibration procedures.

4.3 Back Lit

The instrument is provided with user selectable Back-lit for taking measurements in poor lighting conditions / dark areas. Refer section 11 on page 14 for switching ON / OFF the backlit from the menu.



By pressing "↔" and "ON/OFF" key simultaneously during power ON, the back-lit can be switched ON.

Insulation Resistance Measurement

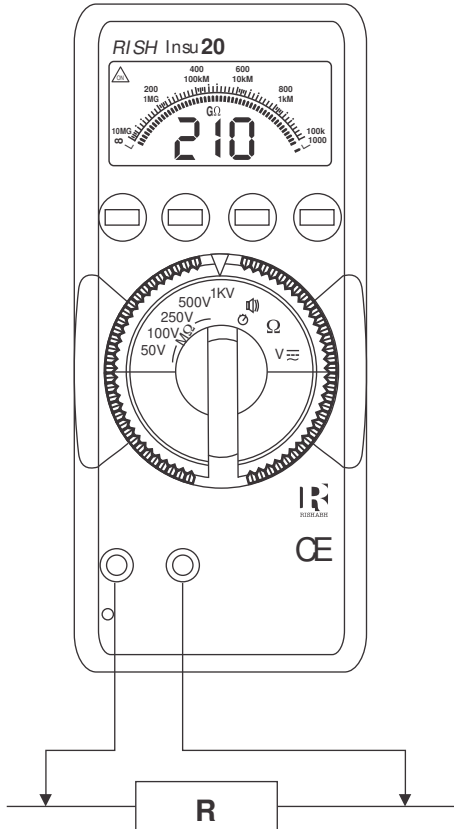

Note

During Insulation resistance measurement the  symbol flashes as long as the high voltage is present at the terminals

5. Insulation Resistance Measurement (MΩ)

5.1. Preparation for measurement

- Select the required "Test Voltage (50V/100V/250V/500V/1000V)" by changing the "Function Selector Switch".
- Connect the test probes firmly to the circuit under test.



Note !

Insulation resistance can only be measured at voltage free object. Hence the circuit under test must be switched off, de-energized and isolated before carrying out any insulation resistance measurement.

When measuring high-ohmic insulation resistance do not touch the measurement cables.

If an interference voltage > 25V is present within the system, insulation resistance measurement is disabled. The instrument defaults to the default voltmeter and displays the value of the interference voltage on the LCD. Also the instrument indicates this additionally by an acoustic signal.



HIGH-VOLTAGE

Do not touch the conductive ends of the test probes after insulation resistance measurement has been activated at the instrument.

A current with a value of 2 mA (limited by the instrument) may flow over your body, and although this is not life endangering, the electric shock is distinctly perceptible.

If you are taking a measurement at a capacitive device under test, for example a cable, it may be charged with as much as 1000V, depending upon the selected nominal voltage. Touching the device under test after measurement may be life endangering in such cases!

5.2 Insulation resistance measurement

The instrument provides flexibility for both manual and continuous (for a pre-selectable time) insulation - resistance measurement.

5.2.1 Manual Insulation resistance measurement :

In manual Insulation resistance measurement, Press and hold "TEST" key until the display has stabilized. Insulation resistance measurement is ended when the yellow TEST key is released. Instrument will continue to show the last reading for few seconds even after releasing the "TEST key".



Note !

The instrument's batteries are depleted during insulation resistance measurement. Only press and hold the TEST key as long as it is necessary to take the reading in the manual measurement mode. Continuous measurement as described below should be performed, if absolutely necessary.

5.2.2 Continuous measurement for a pre-selectable time :

In normal course, the insulation test terminates when the test key is released and the measured insulation resistance value remains on display for few seconds after the test key is released. With the **Pre-selectable measurement time** feature, the insulation test continues for the pre-determined time.

Pre-selectable time : 10 sec-5 min

Refer to the "11. Menu structure" section for how to set the value for pre-selectable time. Once the time is set it is applicable to all the 5 ranges of Insulation measurement.

- Select the required value of the time for which the test is to be carried out.
- Briefly Press the TEST key. The insulation resistance test carries on for the time interval selected.
- The test terminates automatically after the selected time has elapsed.
- The display then flashes the value of measurement at the end until the  Key is pressed.

5.3 Conclusion of measurement and discharging

After the measurement has been completed, any residual voltage is displayed which may be caused by capacitive circuits. Contact with the device under test must be maintained. The reduction in voltage can be directly observed at the LCD.

Do not disconnect the device under test until voltage has dropped below 25 volts !!

Note : Automatic discharge !

The capacitive circuits are automatically discharged when TEST button is released following an insulation resistance test. This auto discharge facility eliminates the need for the user to discharge the circuit under test manually.

6 Additional Features

Additional features available in Insulation measurement ranges.

1. Pre-selectable limit checks (Go/NoGo option)
2. Storing the measured resistance value
3. Minimum and Maximum value "MIN/MAX" storage

6.1 Pre-selectable limit checks (Go/ No-Go option)

An acoustic signal can be generated when the measured value of resistance falls below an adjustable noGo value.

A separate noGo value can be set for each range of insulation resistance measurement as well as for Ohms, Continuity ranges. Refer to the "11. Menu structure" section for how to set the value for the noGo value.

6.2 Storing the measured resistance value

- To store the value of resistance press "STORE" key when the resistance measurement is in progress. This will store the resistance measured at the instant the key is pressed.
- This way maximum 10 readings per range can be stored.
- After 10 values are stored for the selected range the 11th value when stored will over-write the first value i.e. at any given point of time only ten readings per range can be stored.
- The readings are stored in a volatile memory. Therefore when the instrument is switched off, the readings are lost.

Recalling the stored values

The stored values can be recalled and viewed in the menu structure.

Refer to the "11. Menu Structure" section for how to view the stored value.

6.3 Minimum value and Maximum value "MIN/MAX" storage facility (for all measuring ranges)

With the MIN/MAX function, you can hold the minimum and the maximum measured value which was applied to the input of the instrument after activating MIN/MAX. The most important application is determination of minimum and the maximum value for long term monitoring of measured quantities.

The function MIN/MAX can be activated in all measuring ranges. MIN/MAX does not influence analog indication, you can still read the actual measured value.

Apply the measured quantity to instrument prior to activating MIN/MAX function.

The MIN/MAX function is switched off when.

1.  Key is pressed for approximately for 1 Sec. OR
2. Then function selector switch is operated OR
3. When the instrument is turned OFF and ON again

Function MIN/MAX		Measured Value MIN and MAX	Meter reaction			
			Display		Sound signal	
			Measured value	Digital		MIN/MAX
1. Activate and store	short ↓	Stored	Actual measured value		MIN/MAX flash	1x
2. Store and display	short ↓	Stored continued in background new MIN and MAX values are displayed	Stored MIN value		MIN flash	1x
	short ↓		Stored MAX value		MAX flash	
3. Return to 1.	short	Same as 1. Stored values are not cleared	Same as 1.		Same as 1.	1x
Reset	long	Cleared	Cleared		Cleared	2x

Continuity Test

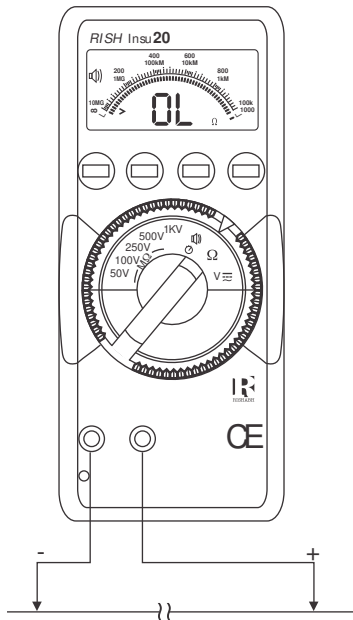
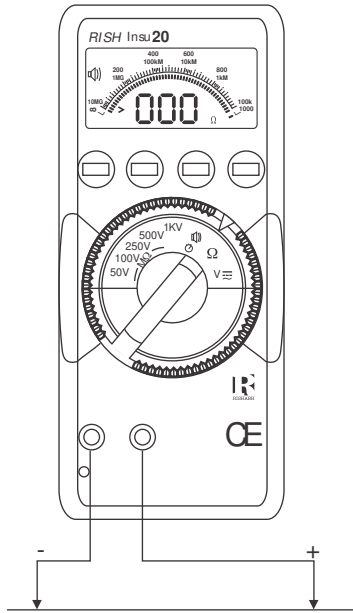

7. Continuity Testing and Resistance Measurement



Attention!
Be absolutely certain that the device under test is voltage-free.

7.1 Continuity Testing

- * Verify that device under test is electrically dead.
- * Set the function selector switch to “” position.
- * If required null lead resistance by doing Zero adjustment below.
- * Connect the device under test as shown in diagram.
- * The measured resistance value will be displayed on the display.
- * The instrument generates a continuous sound signal if the measured resistance value is less than the pre-setted “GoNoGO” value. Default value is 5Ω

Refer to the “11. Menu structure” section for how to set the value for the limit value.

7.2 Low Ohm Measurement (Ω)

- * Verify that device under test is electrically dead.
- * Set the function selector switch to “Ω” position.
- * If required null lead resistance by doing zero adjustment below.
- * Connect the device under test as shown in diagram
- * The measured resistance value will be displayed on the display.
- * The instrument generates a continuous sound signal if the measured resistance value is less than the pre-setted “GoNoGO” value. Default value is 0Ω

Refer to the “11. Menu structure” section for how to set the value for the limit value.

7.3 Zero adjustment

When measuring very low resistance values, you can eliminate resistance of leads and contact resistance by zero adjustment.

- * Connect the test leads to instrument and connect the free ends of the leads to one another.
 - * Wait for reading to stabilize.
 - * Briefly press the “TEST” push button. The instrument acknowledges zero adjustment by a sound signal and the LCD shows “0.00” (+1 digit) and the symbol “ZERO” (17) is displayed. The resistance measured at the instant the push button is pressed is used as reference value (0-9.99Ω). It is automatically deducted from the values measured thereafter.
 - * Zero adjustment can be cleared.
 - > By pressing the “TEST” button once again.
 - > By switching the instrument off.
- Also zero adjustment is cleared when Auto shutOFF operates.

Additional features available in Ohm and Continuity ranges.

1. Pre-selectable limit checks (Go/Nogo option)
2. Storing the measured resistance value.
3. Minimum and Maximum value “MIN/MAX” storage.

8. Voltage Measurement (V AC/DC)

You can use this instrument for voltage measurement from 25V to 600V AC or DC.

- * Keep the function selector switch to "V" position and apply the input.
- * The instrument automatically displays whether the input is AC or DC along with the value of the external voltage.
- * If the value of voltage is < 25V (AC or DC), the display "025V" flashes. If the value of the voltage is > 600V (AC or DC), a continuous acoustic signal is generated.
- * When reverse DC is applied it displays "-dc"

Additional features available in Insulation measurement ranges.

1. Minimum and Maximum value "MIN/MAX" storage

Voltage Measurement

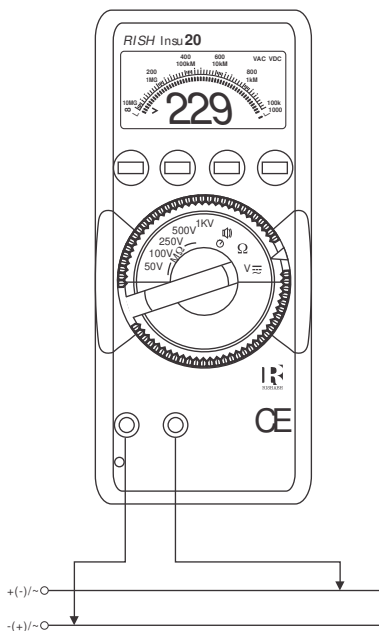

9. Default Live Circuit Warning

When more than 25V (AC or DC) is applied to the terminals the instrument defaults to voltmeter on all switch positions. In addition the beeper will sound on all switch position (except the V position).

When external voltage > 25 V is present, Insulation Ohm and Continuity Tests are inhibited.

When external voltage < 25 V is present, only the Insulation Tests are available !!

Note : The default live circuit warning does not operate
 (i) when in STOPWATCH mode.
 (ii) when in MENU structure.

10 Stop Watch

This function allows you to measure elapsed time up to one hour. To use stop-watch

1. Set the function selector switch to Continuity " " position.
2. Press "TEST" key. This will show the stopwatch from 00:00
3. Press [←] key at any time to RESET the stopwatch.
4. Press [↑] key at any time to START or STOP the stopwatch.
5. To quit stopwatch and go back to basic display, Press "TEST" key.

11 Menu Structure

Structure of command menu for Insulation measurement :

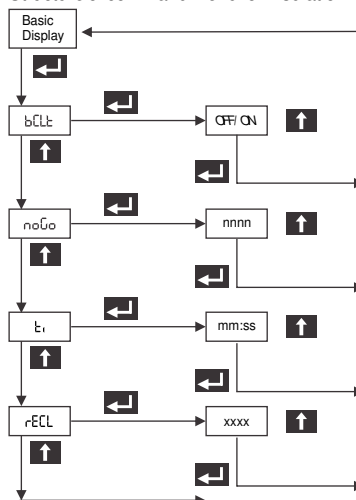

Structure of command menu for Resistance & Continuity measurement

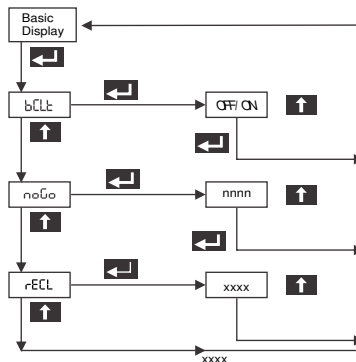

- OFF = Backlit off
- ON = Backlit on
- t = Time
- rECL = Recall
- mm = Minutes
- ss = Seconds
- nnnn = Value for noGo
- xxxx = Stored value

Structure of command menu for Voltate measurement

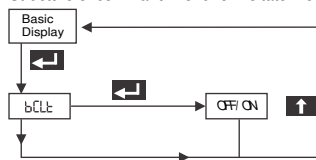

- [←] = Confirmation of selected menu item via ENTER key
- [↑] = Select next menu item in the flow direction
- Esc = Go back to previous level of menu

11.1 Description of Menu Items :

11.1.1 Setting Backlit OFF/ON : (at all ranges)

Basic Display bCLt OFF/ON

1. Now scroll through ON/OFF values using the key until you come across required value.
2. To save this value press key. After saving, this will take you to basic display.
3. To go back without saving press "ESC" key. This will take you to main menu "bCLt"
4. To go back to basic display from main menu "bCLt" use "ESC" key.

11.1.2 Setting the GoNoGo values :

(at all ranges except V)

Operating Order :

Basic Display bCLt noGo nnnn

Setting : nnnn = noGo limit values in M Ω /G Ω (for Insulation ranges)
nnnn = noGo limit values in Ω (for Ohm and Continuity)

1. Now scroll through different values using the key until you come across required value.
2. To save this value press key. After saving, this will take you to basic display.
3. To go back without saving press "ESC" key. This will take you to main menu "noGo"
4. To go back to basic display from main menu "noGo" use "ESC" key.

11.1.3 Setting the Timer values

(Only at Insulation Resistance measurement ranges)

Operating Order :

Basic display bCLt noGo ti mm:ss

Setting : mm= minutes, ss = seconds

1. Now scroll through different values using the key until you come across required value.
2. To save this value press key. after saving, this will take you to basic display.
3. To go back without saving press "ESC" key. This will take you to main menu "ti"
4. To go back to basic display from main menu "ti" use "ESC" key.

11.1.4 To see the stored values

(at all ranges except V)

Operating Order :

Basic display bCLt noGo ti reCL nnnn

1. You can now see the first stored value. The scale pointer is used to indicate the number (out of 10) of the displayed stored value.
2. Now you can view the successive stored value using the key. The scale pointer also increments to indicate the number (out of 10) of the displayed stored value.
3. To go back press "ESC" key. This will take you to main menu "reCL"
4. To go back to basic display from main menu "reCL" use "ESC" key.

Table for default values :

	NoGo	ti	reCL
50V	1 M Ω	00:00 (Manual)	0.00
100V	1 M Ω		0.00
250V	5 M Ω		0.00
500V	5 M Ω		0.00
1000V	500 M Ω		0.00
Ohm	00 Ω	---	0.00
Cont	5 Ω	---	0.00
V	---	---	---

12. Specifications

Meas. function	Range	Resolution	Accuracy \pm (..% of rdg + .. digit)	Overload value and duration
Insulation Resistance M Ω ¹⁾ U _N = 50 V, 100 V	0.01 M Ω to 0.99 M Ω	10 K Ω (0.01 M Ω)	\pm 3% \pm 2	1200V rms, 10 sec
	\geq 1.0 M Ω to 9.9 M Ω	100 K Ω to (0.1M Ω)	\pm 5% \pm 2	
	\geq 10 M Ω to 999 M Ω	1 M Ω	\pm 30%	
Insulation Resistance M Ω /G Ω ¹⁾ U _N = 250 V, 500 V, 1000 V	0.01 M Ω to 9.99 M Ω	10 K Ω (0.01 M Ω)	\pm 5% \pm 2	1200V rms, 10 sec
	\geq 10.0 M Ω to 99.9 M Ω	100 K Ω to (0.1M Ω)	\pm 5% \pm 2	
	\geq 100 M Ω to 999 M Ω	1 M Ω	\pm 30%	
Low Ohms ²⁾ Ω	0-9.99 Ω	0.01 Ω at 210 mA	\pm 3% \pm 2	1200V rms, 10 sec
	\geq 10 Ω -99.9 Ω	0.1 Ω at 21 mA	\pm 5% \pm 2	
Continuity ²⁾	0-9.99 Ω	0.01 Ω at 210 mA	\pm 3% \pm 2	1200V rms, 10 sec
	\geq 10 Ω -99.9 Ω	0.1 Ω at 21 mA	\pm 5% \pm 2	
V AC/DC	\geq 25V-450V	1 V	\pm 2% \pm 3	1200V rms, 10 sec
	\geq 450V-600V	1 V	\pm 3	

1) For insulation resistance range, 2) For low Ohms/continuity Ranges

* Terminal voltage on open circuit (DC)
-0% to +30% of rated voltage

* Short circuit current < 2 mA

* Test current on load 1 mA at minimum pass values of insulation as specified in VDE 0413 Part 1.

* Open circuit voltage 5V \pm 1V d.c.

* Lead resistance compensation : 0 - 9.99 Ω

Reference Conditions :

Ambient Temp. +23°C \pm 2 K
Relative Humidity 45%...55%
Battery Voltage 8V \pm 0.1 V
Voltage Measurement AC (Sine), 50/60 Hz

Display

LCD display field (65 mm x 30 mm) with analog indication and Digital display and with display of unit of measured quantity and functions

Analog

Display Logarithmic Scale

Digital

Display/Char. Height 7 segment digits/12mm

Number of Digits 3 digit for MΩ and Ω

 4 digit for Stop watch

Over range Indication OL

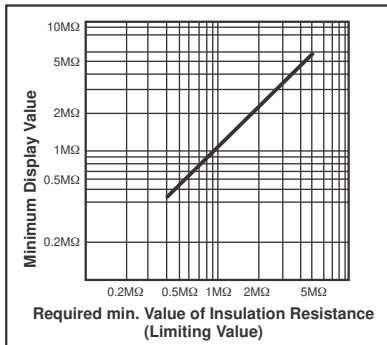
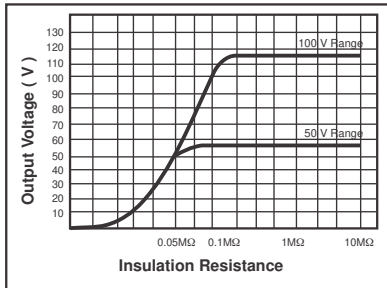
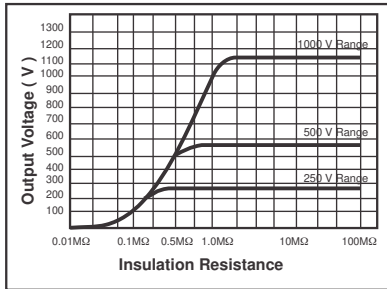

Power Supply

Battery

6 x 1.5V cells IEC LR6
(Nickel cadmium rechargeable cells may be used)

Service Life

Without Backlit ON : Typically 2500x5 sec.
Operation with alkaline manganese cells.
With Backlit ON : Typically 1250x5 seconds
Operation with alkaline manganese cells.

Battery Test

Battery symbol "—|—" appears on the LCD in either of below conditions :

1. Battery voltage is <5.4V. Battery replacement is necessary.
2. For a specific range depending on application

In either of the above condition, when the battery symbol is displayed, no measurement can be done, and the battery symbol flashes.

Note : Battery cells should not be left in the instrument which may remain unused for extended period of time.

Mains Adapter (Optional)

Input : 100-240 VAC, 50/60 Hz

Output : 12 VDC, 1000 mA



Auto turn OFF

Instrument turns off automatically, if any of the keys or the function selector switch have not been activated for about 10 minutes in insulation resistance range and 5 minutes in other ranges.

Cable Set

Cu cross-sectional area 1 mm²

End metallic parts should pass terminal \varnothing 4 D 11

Technical data as per IEC 61010 / EN 61010-2-031 CATIII/1000V, Air/creepage \geq 16 mm.

High Voltage test 7.4kV AC for 1 min.

Breaking force of the cable \geq 36N, 1 min.

Fuse

500 mA(F) / 440V H.B.C. 10 kA min (32mm x 6mm)

Electrical Safety

Protection Class

II per IEC 61010-1/EN61010-1/VDE0411-1

Over voltage

Category

II

III

Nominal Voltage

600V

300V

Contamination degree

2

2

Test Voltage

3.7KV~per IEC 61010-1/EN61010-1

EMC

IEC/EN 61326

Electromagnetic Compatibility (EMC)

Environmental Conditions

Nominal Temp. Range 0.....35°C

Operating Temp. -20°C... + 40°C (full range)

 -20°C... + 60°C (up to 100 MΩ)

Storage Temp -25°C...+65°C

Relative Humidity 90% RH at 40°C max.

Temperature Coefficient <0.1%/per°C

Mechanical Design

Protection	Instrument :IP 50 For terminal socket : IP 20 according to DIN VDE 0470 Part 1 / EN60529
Dimensions	W x H x D 84mm x 195 mm x 35 mm
Weight	500 g including battery

13 Maintenance



Attention !
Disconnect the instrument from the measuring circuit before opening the instrument to replace the battery or the fuse !

13.1 Battery

Before initial Start-up, or after long storage of your instrument, make sure that no leakage has occurred at the instrument battery. Repeat this inspection at regular intervals.

Battery symbol " " appears on the LCD in either of below conditions :

1. Battery voltage is <math>< 5.4 \text{ V}</math>. Battery replacement is necessary.
2. For a specific range depending on application

In either of above condition when the battery symbol is displayed, no measurement can be done, and the battery symbol flashes.

Replacing the Batteries

- * Lay the instrument on to its face, loosen the two screws at the rare panel and lift out the housing base, starting at the bottom (a). The housing base and the housing top are held together with snap hooks at the top of the front panel.
- * Remove all the cells from the battery holder and replace them with new ones.
- * Important for reassembly : first lay the housing base into place such as shown in diagram below. Push the housing base and housing top together, first at the bottom front (a) and then at the top front (b).

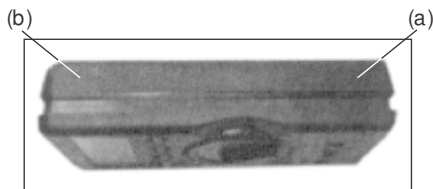

- * Retighten the housing base with the two screws.
- * Please dispose of the used cells properly.

13.2 Operation with Mains Adapter (Optional)

Use only Mains Adapter (Output : 12VDC, 1000mA) to power ON the instrument.

During power supply via mains adapter in inserted batteries are cut off electronically and thus can be left inside the instrument.



Note : There is no need of internal batteries when AC-DC Adapter is connected to the instruments.
If re-chargeable batteries are used they must be charged outside the instrument.

13.3 Fuses

Application of high energy pulse during Insulation resistance measurement or application of voltage during Continuity and Ohm measurement will blow the fuse. If the fuse blows, eliminate the cause of the overload before placing the instrument back in to operation !

Fuse Testing

- * Set the function selector switch to any insulation measurement range.
 - * Open circuit the test leads.
 - * Press the "Test" button until "OL" or "FUSE" appears on display.
- If display = "OL" : Fuse is OK.
If display = "FUSE" : Fuse is blown and needs replacement.



Note : Once "FUSE" is displayed all the functions are inhibited. Immediately switch the Instrument OFF and replace the fuse.

Replacement of Fuses

- * Open the instrument as described under battery replacement.
- * Remove the defective fuse and replace it with a new fuse.
- * Make sure that the new fuse makes good contact.

Specification :

Current Rating : 500 mA / 500V-6.3 mm x 32 mm with a breaking capacity of 10kA.

Recommended fuse manufacturer : Siba

Part No. : 70-065-63/0.5A



Be absolutely sure that only the specified fuses are used !
The use of a fuse with different triggering characteristics, a different nominal current or a different breaking capacity exposes the operator, the system and the measuring instrument to danger. The use of repaired fuses or short-circuiting of the fuse holder is prohibited.

13.4 Housing

No special maintenance is required for the housing. Excessive contamination has an adverse effect on isolation and reduces input resistance. The surface must be kept clean for this reason. Use a slightly dampened cloth for cleaning. Oil free petrol is recommended for cleaning. Avoid the use cleansers, abrasives or solvents.